

KEL

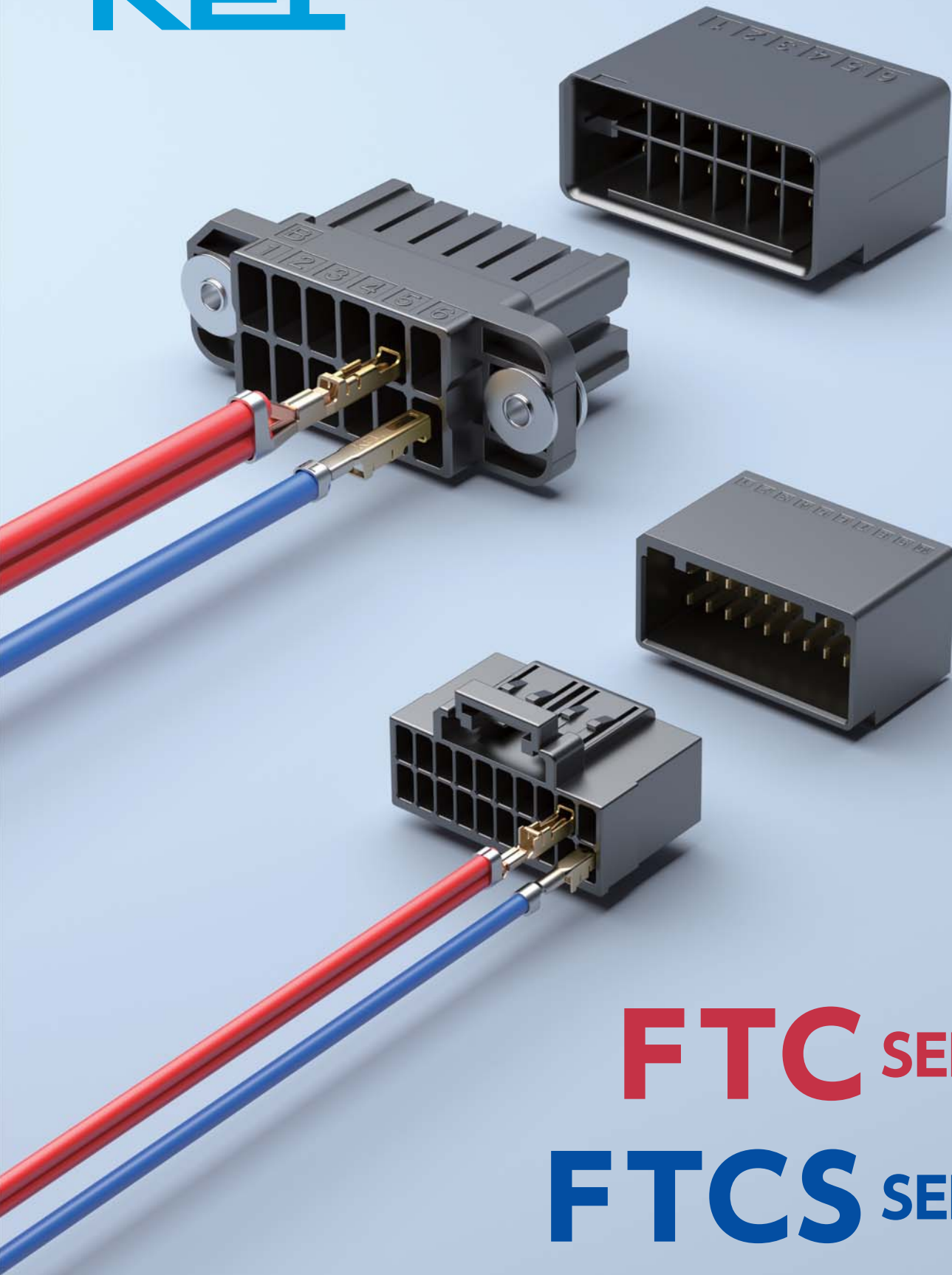

FTC SERIES

FTCS SERIES

**A compact type for FTC series
that enables 2 wires crimping**

FA equipment (Servo/Robot)



Medical (Analytical equipment)



Elevator



Cables in equipment will become



Semiconductor manufacturing equipment



Electric power/
Power generation equipment



Printing
equipment



SW power supply

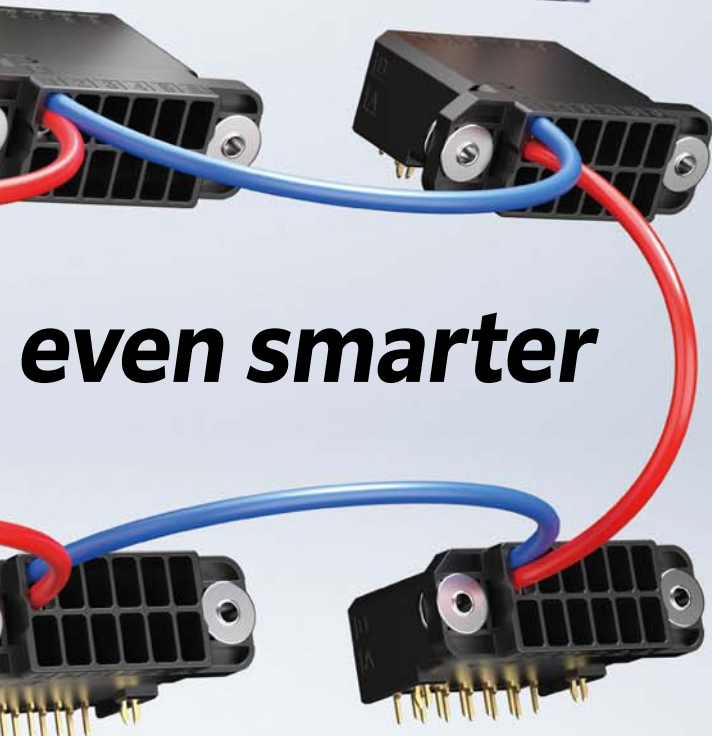

Communication
(Electronic exchanging equipment)

FTCS

2.5mm pitch
Cable crimping connector

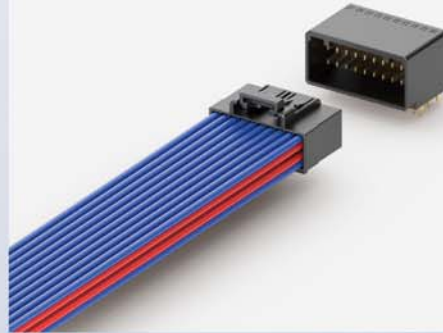

FTC

5.08mm pitch
Cable crimping connector



Its compact size allows for a wide range of designs.

FTC series with 5.08mm pitch saves space for cables in equipment by two wires crimping. By introduction of the compact 2.5mm pitch FTCS series, it can be used in a wide range of designs.

Eliminates disadvantages with terminal block

When connecting multiple connectors, FTC/FTCS series are not required any terminal blocks and can be connected using only the connectors. This eliminates the terminal block installation space, termination work and reduction in working time.

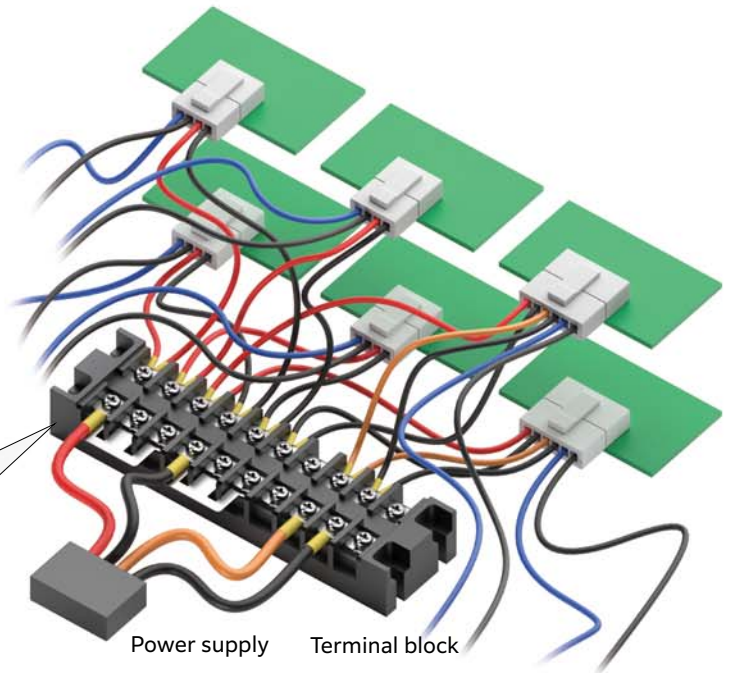
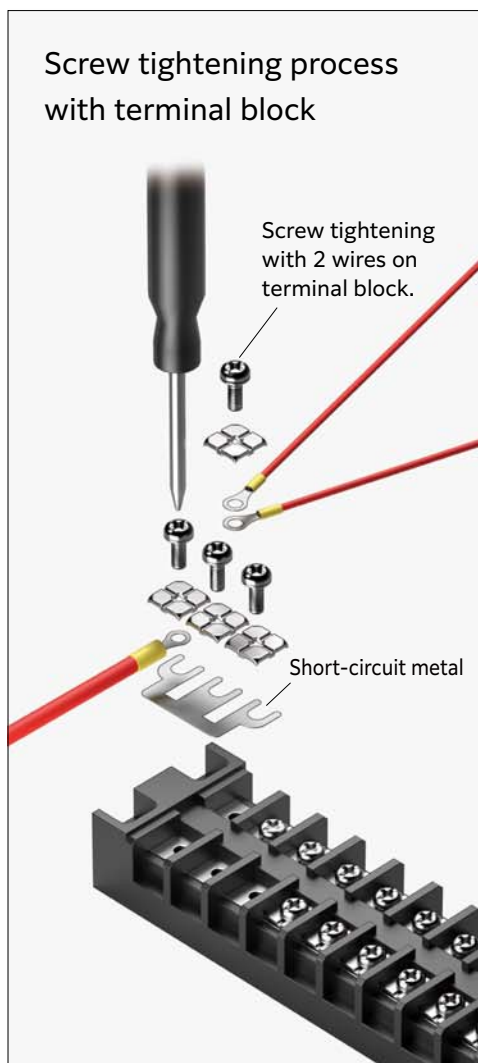

Without FTC/FTCS series

- ➔ Wiring process with terminal block
- ➔ Installation space for terminal block

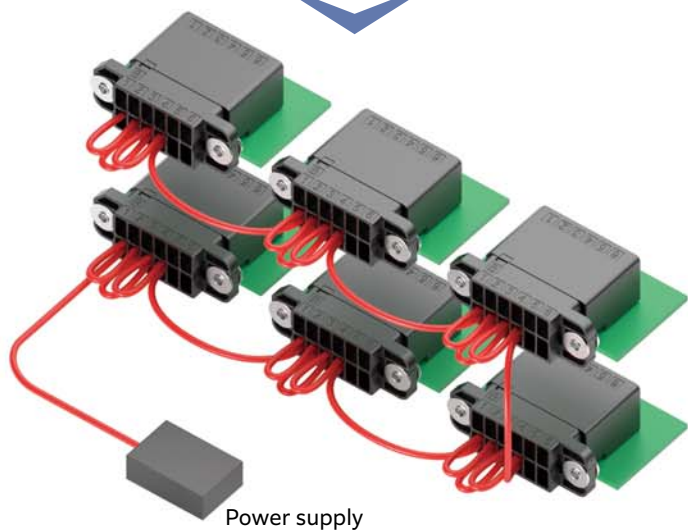

With FTC/FTCS series

- ➔ No wiring process with terminal block
- ➔ No installation space for terminal block

Branch termination is available by 2 wires crimping.

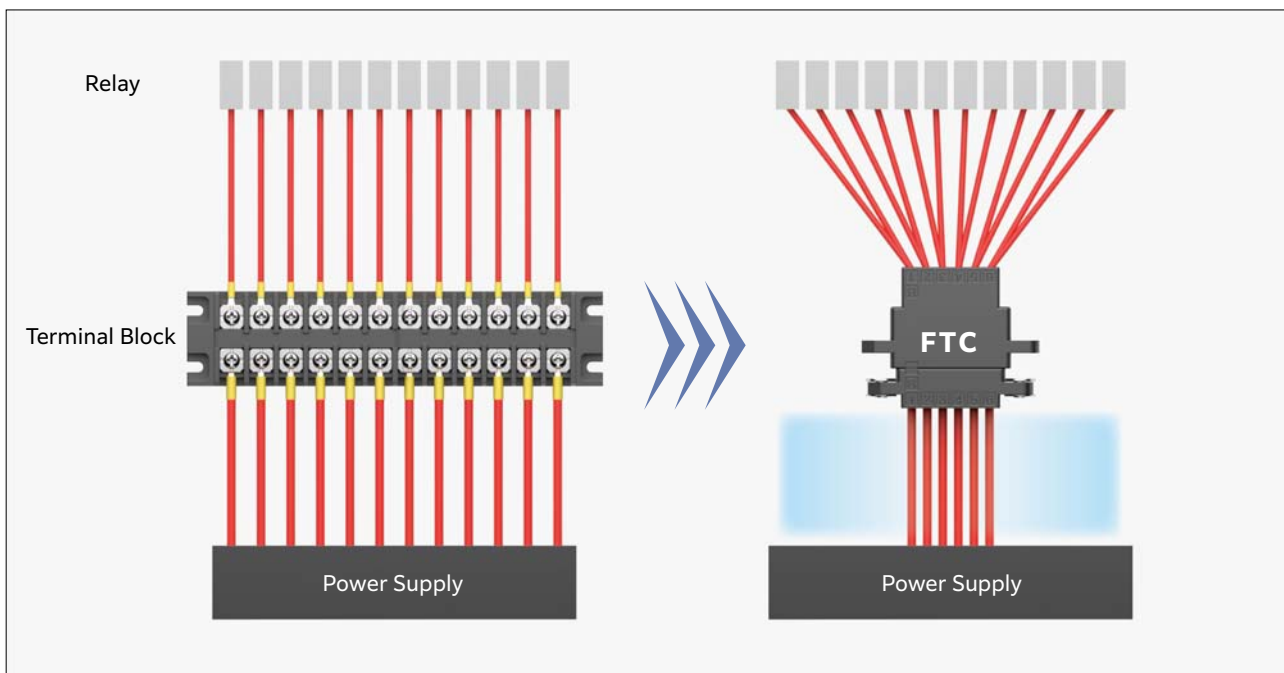

Cable counts will be reduced in half

Space saving



KEL's 2 wires crimping is covered by our manufacturer's warranty.

KEL guarantees the quality and reliable of harness by 2 wires crimping.

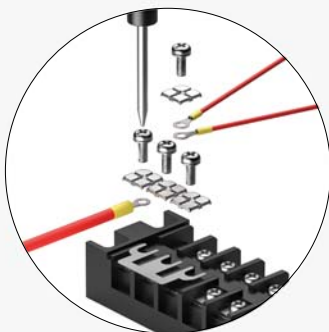

Reduction of the working process for complicated wiring and screw tightening on terminal blocks.

By 2 wires crimping, you are able to be freed from complicated cable termination and screw tightening process on terminal blocks.



Reduction for cable counts in the equipment

The power distribution and branching structure contributes for the reduction of cables in the equipment.

Slimming of internal cable wiring

Provides contacts for 2 wires crimping

Available contact selection for 1 wire or 2 wires

A feature of crimp connectors is that the terminals with crimped wires can be assembled in any location. In the FTC/FTCS series, terminals with 2 wires crimping can also be inserted anywhere. Therefore, you can create a harness assembly by selection of 1 wire crimping or 2 wires crimping.

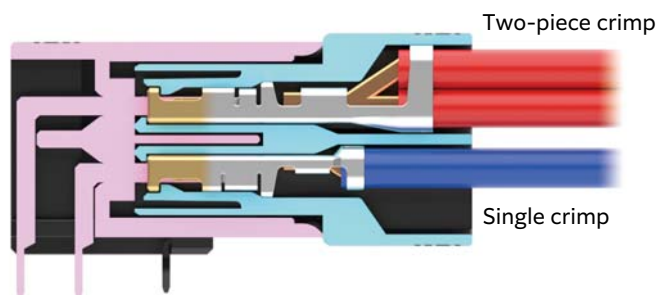

Combine Input and Output per contact

By two cables crimping to one terminal, you can use the first wire as Input and the second wire as Output. Daisy chain wiring is also perform between connectors.

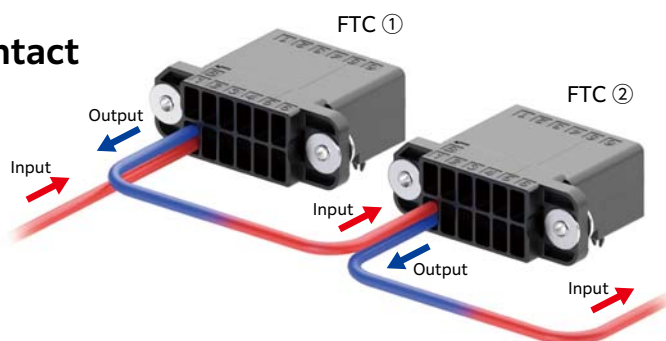

Contacts reduction and space saving by 2 wires crimping

If you crimp one wire to a contact, the number of terminal and the number of wire are the same. However, the number of contacts can be reduced by 2 wires crimping to the terminal. It also contributes to space saving.



Conventional

Number of wires: 24 wires
Number of contacts: 24 pins



2 wires crimping

Number of wires: 24 wires
Number of contacts: 12 pins

Mating Variation

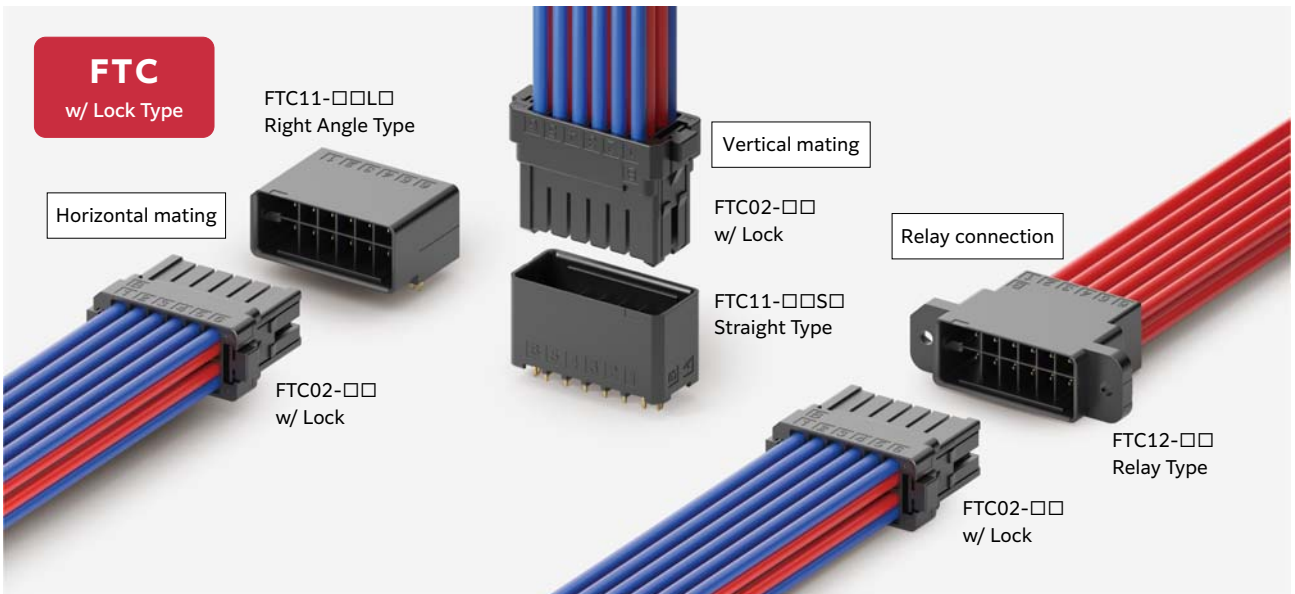
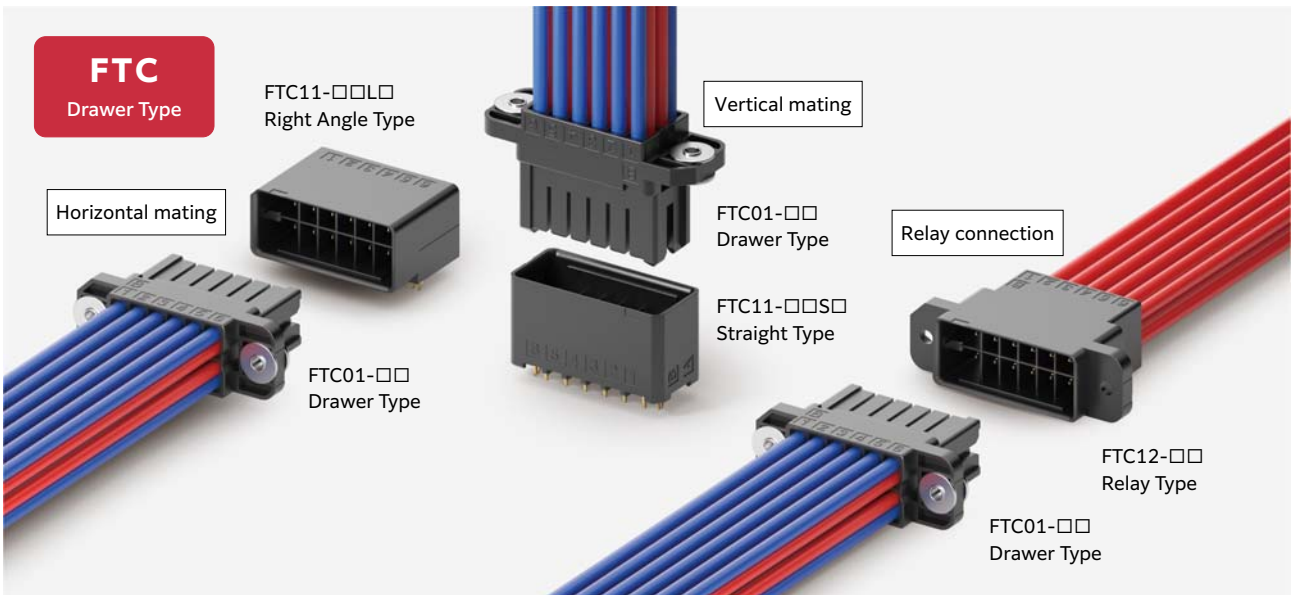
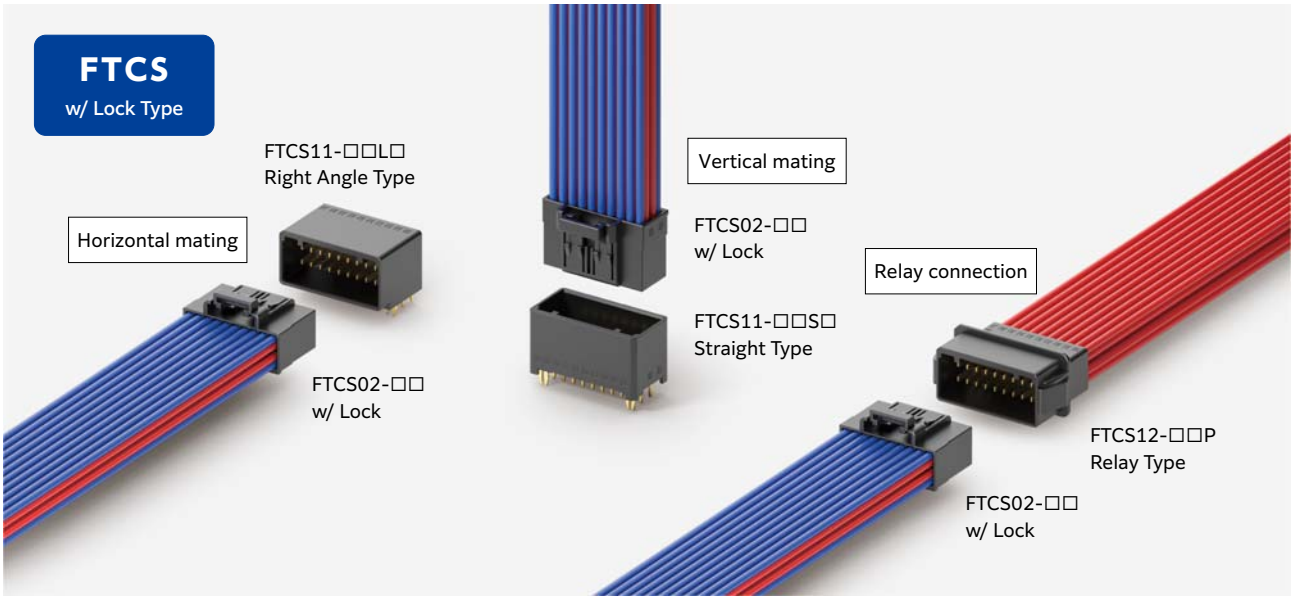

Receptacle

Cable side connector

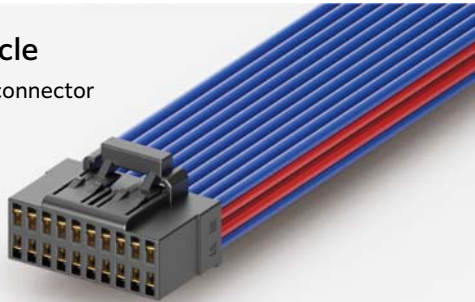

w/ Lock type
FTCS02-□□

Plug

Cable relay type



FTCS12-□□P

Plug

PCB side connector



Straight type
FTCS11-□□S□



Right angle type
FTCS11-□□L□

Specification

Material and plating

Insulator material	Glass-filled PBT (UL94V-0), Black
Contact material	Copper alloy
Contact plating	[FTCS02/12] (Contact area) Gold over Nickel (Crimp area) Nickel over Nickel [FTCS11] (Contact area) Gold over Nickel (Terminal area) Gold over Nickel
Retention clip material	Copper Alloy
Retention clip plating	Gold over Nickel

Electrical characteristics

Rated current	See page 9 [Standard Rated current] [Rated current for UL]
Rated voltage	250V AC-DC
Contact resistance	10mΩ max.
Dielectric withstanding voltage	1,500V AC for 1 minute
Insulation resistance	1,000MΩ min. at 500V DC
Operating temperature	-55°C to +105°C
Durability of insertion and withdrawal	[Gold plating thickness 0.1μm min.] 100 times [Gold plating thickness 0.38μm min.] 500 times
Applicable cable	AWG#18/20/22/24/26/28 (Outer diameter of cable coating: Φ0.88 to 2.03mm) Discrete wire cable

Order Code

FTCS02-□□*

① ②

- ① [Type] **FTCS02** : Receptacle (Cable side connector) with lock type
- ② [Number of contacts] **06** : 6 pin **12** : 12 pin **16** : 16 pin **20** : 20 pin

FTCS11-□□□□

① ② ③ ④

- ① [Type] **FTCS11** : Plug (PCB side connector)
- ② [Number of contacts] (Straight type) **06** : 6 pin **12** : 12 pin **20** : 20 pin
(Right angle type) **06** : 6 pin **12** : 12 pin **16** : 16 pin **20** : 20 pin
- ③ [Contact tail style] **S** : Straight **L** : Right angle
- ④ [Gold plating thickness] **B** : 0.1μm min. **F** : 0.38μm min.

FTCS12-□□□P*

① ② ③

- ① [Type] **FTCS12** : Plug (Cable-relay type)
- ② [Number of contacts] **06** : 6 pin **12** : 12 pin **20** : 20 pin
- ③ [Style] **P** : Panel mount type

#674□-□

① ② ③

- ① [Contact name] **#674** : Crimp contact for FTCS02 series
- ② [Gold plating thickness] **B** : 0.1μm min. **F** : 0.38μm min.
- ③ [Applicable cable size]
 - S** : Single crimp AWG#22/24/26/28(Outer diameter of cable coating: Φ0.88 to 1.58mm)
Two-piece crimp AWG#26 x 2 pieces(Outer diameter of cable coating: Φ0.98 to 1.3mm x 2 pieces)
Two-piece crimp AWG#28 x 2 pieces(Outer diameter of cable coating: Φ0.88 to 1.2mm x 2 pieces)
 - M** :Single crimp AWG#18/20/22(Outer diameter of cable coating: Φ1.58 to 2.03mm)
Two-piece crimp AWG#20 x 2 pieces(Outer diameter of cable coating: Φ1.58 to 1.87mm x 2 pieces)
Two-piece crimp AWG#22 x 2 pieces(Outer diameter of cable coating: Φ1.30 to 1.68mm x 2 pieces)
Two-piece crimp AWG#24 x 2 pieces(Outer diameter of cable coating: Φ1.12 to 1.43mm x 2 pieces)

#677□-□

① ② ③

- ① [Contact name] **#677** : Crimp contact for FTCS12 series
- ② [Gold plating thickness] **B** : 0.1μm min. **F** : 0.38μm min.
- ③ [Applicable cable size]
 - S** : Single crimp AWG#22/24/26/28(Outer diameter of cable coating: Φ0.88 to 1.58mm)
Two-piece crimp AWG#26 x 2 pieces(Outer diameter of cable coating: Φ0.98 to 1.3mm x 2 pieces)
Two-piece crimp AWG#28 x 2 pieces(Outer diameter of cable coating: Φ0.88 to 1.2mm x 2 pieces)
 - M** :Single crimp AWG#18/20/22(Outer diameter of cable coating: Φ1.58 to 2.03mm)
Two-piece crimp AWG#20 x 2 pieces(Outer diameter of cable coating: Φ1.58 to 1.87mm x 2 pieces)
Two-piece crimp AWG#22 x 2 pieces(Outer diameter of cable coating: Φ1.30 to 1.68mm x 2 pieces)
Two-piece crimp AWG#24 x 2 pieces(Outer diameter of cable coating: Φ1.12 to 1.43mm x 2 pieces)

*Housing only. Contacts are sold separately.

Standard Rated current *

Unit: A (per contact)

Mating matrix		Cable size					
Receptacle	Plug	AWG#18	AWG#20	AWG#22	AWG#24	AWG#26	AWG#28
FTCS02-□□	FTCS11-□□S□	6.0	5.5	5.0	4.0	3.5	2.5
	FTCS11-□□L□	5.5	5.0	4.5	4.0	3.5	2.5
	FTCS12-□□P	6.5	5.5	4.5	3.5	2.5	2.0

*Current rating is when using all of 20 pins are energized. The current rating varies depending on the number of energized contacts

Rated current for UL UL1977 *UL cUL File No. E509060

Unit: A (per contact)

Mating matrix		Cable size					
Receptacle	Plug	AWG#18	AWG#20	AWG#22	AWG#24	AWG#26	AWG#28
FTCS02-□□	FTCS11-□□□□	5.0		3.5			2.0
	FTCS12-□□P						

Assembly Tool

Crimping hand tool

Part number	Crimp contact	Number of cables	Applicable cable size
CH-24	#674□-S	1	AWG#22/24/26/28
	#677□-S		
CH-25	#674□-S	2	AWG#26/28 x 2
	#677□-S		
CH-26	#674□-M	1	AWG#18/20/22
	#677□-M		
CH-27	#674□-M	2	AWG#20/22/24 x 2
	#677□-M		

Crimping machine

Applicator	Crimp contact	Crimping machine	Manufacturer
CFX105700K	#674□-S	LPC220S	Japan Automatic Machine Co., Ltd.
	#677□-S		
CFX105800K	#674□-M		
	#677□-M		

*A crimping machine and applicator can be purchased from Japan Automatic Machine Co., Ltd.

Receptacle

Cable side connector



Drawer type
FTC01-12

w/ Lock type
FTC02-□□

Plug

PCB side connector



Straight type
FTC11-□□S□

Right angle type
FTC11-□□L□

Plug

Cable relay type

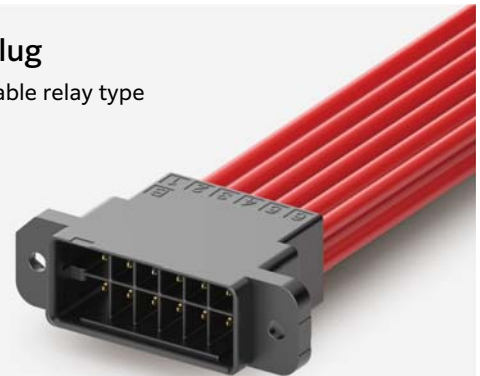

FTC12-□□

Specification

Material and plating

Insulator material	Glass-filled PBT (UL94V-0), Black
Contact material	Copper alloy
Contact plating	[FTC0□/12] (Contact area) Gold over Nickel (Crimp area) Nickel over Nickel [FTC11] (Contact area) Gold over Nickel (Terminal area) Gold over Nickel
Retention clip material	Copper Alloy
Retention clip plating	Gold over Nickel
Washer / Rivet material	Stainless

Electrical characteristics

Rated current	See page 12 [Standard Rated current] [Rated current for UL]
Rated voltage	600V AC-DC
Contact resistance	10mΩ max.
Dielectric withstanding voltage	2,200V AC for 1 minute
Insulation resistance	DC500V 1,000MΩ min.
Operating temperature	-55°C to +105°C
Durability of insertion and withdrawal	[Gold plating thickness 0.1μm min.] 100 times [Gold plating thickness 0.38μm min.] 500 times
Applicable cable	AWG#14/16/18/20 (Outer diameter of cable coating: Φ1.8 to 3.4mm) Discrete wire cable

Order Code

FTC0□-□□*
① ②

- ① [Type] Receptacle (Cable side connector) **FTC01** : Drawer type **FTC02** : w/ Lock type
- ② [Number of contacts] (FTC01) **12** : 12pin
 (FTC02) **06** : 6pin **10** : 10pin **12** : 12pin **20** : 20pin

FTC11-□□□□
① ② ③ ④

- ① [Type] **FTC11** : Plug (PCB side connector)
- ② [Number of contacts] (Straight type) **06** : 6pin **12** : 12pin **20** : 20pin
 (Right angle type) **06** : 6pin **10** : 10pin **12** : 12pin **20** : 20pin
- ③ [Contact tail style] **S** : Straight **L** : Right angle
- ④ [Gold plating thickness] **B** : 0.1μm min. **F** : 0.38μm min.

FTC12-□□*
① ②

- ① [Type] **FTC12** : Plug (Cable-relay type)
- ② [Number of contacts] **06** : 6pin **10** : 10pin **12** : 12pin **20** : 20pin

#625□-1□-□
① ② ③ ④

- ① [Contact name] **#625** : Crimp contact for FTC0□ series
- ② [Gold plating thickness] **B** : 0.1μm min. **F** : 0.38μm min.
- ③ [Applicable cable size]
 - 1M** : Single crimp AWG#18/20(Outer diameter of cable coating: Φ1.8 to 2.8mm)
 - Two-piece crimp AWG#18 x 2 pieces(Outer diameter of cable coating: Φ2.0 to 2.1mm x 2 pieces)
 - Two-piece crimp AWG#20 x 2 pieces(Outer diameter of cable coating: Φ1.8 to 1.9mm x 2 pieces)
- 1L** : Single crimp AWG#14/16(Outer diameter of cable coating: Φ2.4 to 3.4mm)
- Two-piece crimp AWG#16 x 2 pieces(Outer diameter of cable coating: Φ3.0mm x 2 pieces)
- ④ [Type] **R** : Chain shape **B** : In pieces

#625□-2L-□
① ② ③ ④

- ① [Contact name] **#625** : Crimp contact for FTC0□ series
- ② [Gold plating thickness] **B** : 0.1μm min. **F** : 0.38μm min.
- ③ [Applicable cable size]
 - 2L** : Two-piece crimp AWG#14 x 2 pieces(Outer diameter of cable coating: Φ3.4mm x 2 pieces)
- ④ [Type] **R** : Chain shape **B** : In pieces

#641□-1□-□
① ② ③ ④

- ① [Contact name] **#641** : Crimp contact for FTC12 series
- ② [Gold plating thickness] **B** : 0.1μm min. **F** : 0.38μm min.
- ③ [Applicable cable size]
 - 1M** : Single crimp AWG#18/20(Outer diameter of cable coating: Φ1.8 to 2.8mm)
 - Two-piece crimp AWG#18 x 2 pieces(Outer diameter of cable coating: Φ2.0 to 2.1mm x 2 pieces)
 - Two-piece crimp AWG#20 x 2 pieces(Outer diameter of cable coating: Φ1.8 to 1.9mm x 2 pieces)
- 1L** : Single crimp AWG#14/16(Outer diameter of cable coating: Φ2.4 to 3.4mm)
- Two-piece crimp AWG#16 x 2 pieces(Outer diameter of cable coating: Φ3.0mm x 2 pieces)
- ④ [Type] **R** : Chain shape **B** : In pieces

*Housing only. Contacts are sold separately.

Assembly Tool

Crimping hand tool

Part number	Crimp contact	Number of cables	Applicable cable size
CH-21	#625□-1M-□	1	AWG#18/20
	#641□-1M-□	2	AWG#20 x 2
		2	AWG#18 x 2
CH-22	#625□-1L-□	1	AWG#14/16
	#641□-1L-□	2	AWG#16 x 2
CH-23	#625□-2L-□	2	AWG#14 x 2

Crimping machine

Crimp contact	Applicator	Crimping machine	Manufacturer
#625□-1M-R	CFX064300K	LPC220S	Japan Automatic Machine Co., Ltd.
#641□-1M-R			
#625□-1L-R	CFX050300K		
#641□-1L-R			
#625□-2L-R	QFX021900K	LPC420S	

*A crimping machine and applicator can be purchased from Japan Automatic Machine Co., Ltd.

Standard rated current *1

Unit: A (per contact)

Mating matrix		Cable size			
Receptacle	Plug	AWG#14	AWG#16	AWG#18	AWG#20
FTC01-12*2	FTC11-12S□	9.0	8.5	7.5	7.5
	FTC11-12L□	8.5	8.5	7.5	7.5
	FTC12-12	12.0	9.5	7.5	7.5
FTC02-□□*3	FTC11-□□S□	8.0	7.0	6.0	6.0
	FTC11-□□L□	7.0	6.0	5.5	5.5
	FTC12-□□	10.0	8.5	6.5	6.5

*1 The current rating varies depending on the number of energized contacts, Please contact our sales representative for details.

*2 Current rating is when using all of 12 pins are energized.

*3 Current rating is when using all of 20 pins are energized.

Rated current for UL UL1977 *UL cUL File No. E509060

Unit: A (per contact)

Mating matrix		Cable size			
Receptacle	Plug	AWG#14	AWG#16	AWG#18	AWG#20
FTC0□-□□	FTC11-□□□□	7.0	6.0	5.5	5.5
	FTC12-□□	7.0	6.0	5.5	5.5

KEL Company Profile

Trade Name: KEL CORPORATION

Established : July 23, 1962

Total Capital: 1,617 Million Yen

President : Akira Kasuga

Head Office : 6-17-7 Nagayama, Tama,

Address Tokyo 206-0025, Japan

URL : www.kel.jp

Factories

- Yamanashi Factory (Nishi-Yatsushiro, Yamanashi)
- Nagano Factory (Kita-azumi, Nagano)
- Minami-Alps Factory (Minami-Alps, Yamanashi)

Global Network



www.kel.jp

KEL provides the products from a connector to a rack.

KEL CORPORATION

More Information
<https://www.kel.jp/>

